

# VCM for LED chip sorter

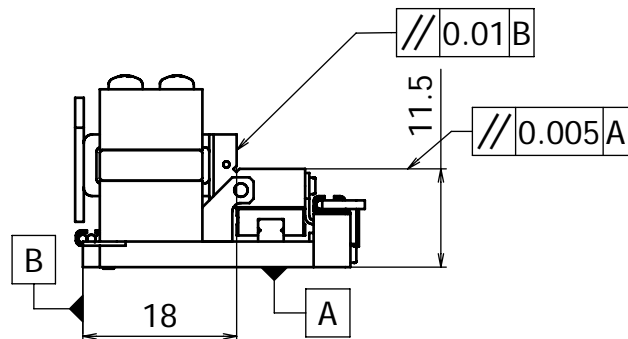
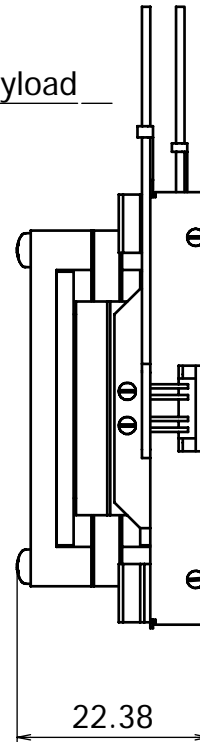
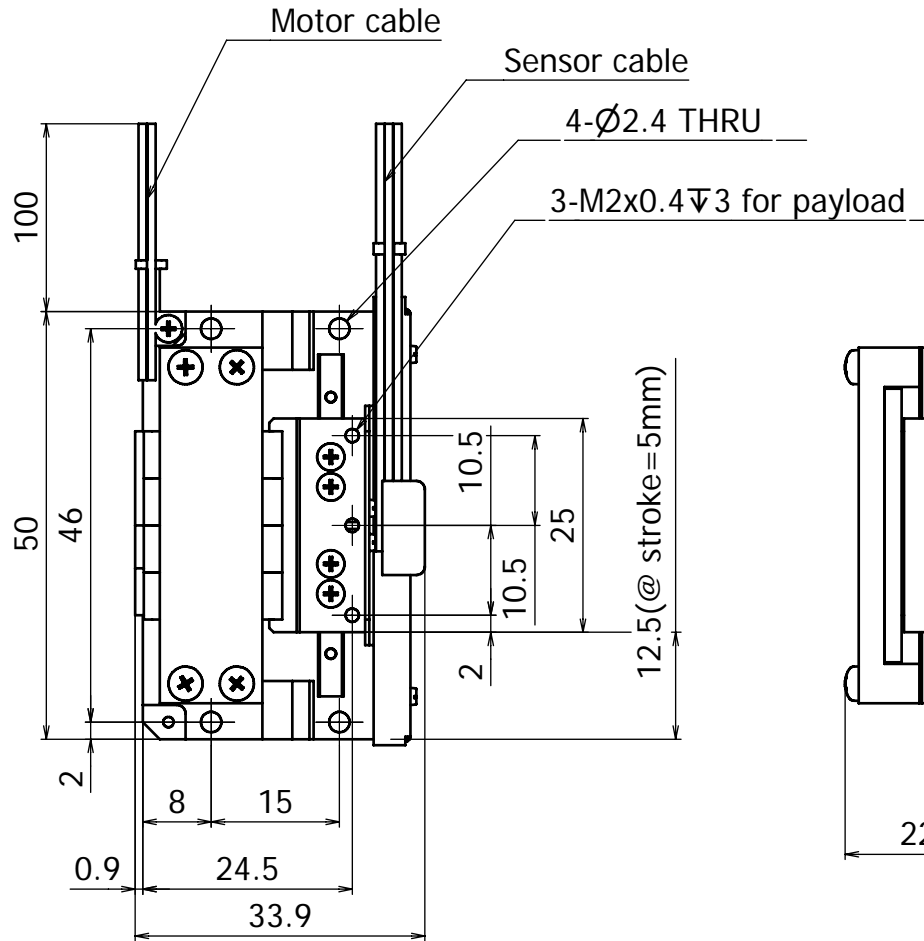
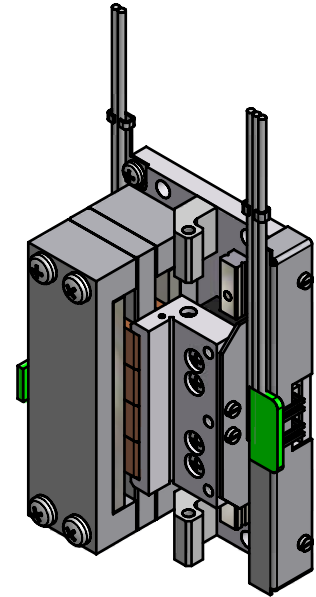

## Specification:

Stroke: 10 mm  
 Resolution: 0.8  $\mu$ m  
 Rated Force: 1 Nt  
 Peak Force: 5 Nt  
 Rated Current: 0.2 A  
 Peak Current: 1 A  
 Driver Voltage: 24V  
 Moving mass: 16 g  
 Total mass: 87 g

## Features:

1. Space saving: extremely small profile.
2. Excellent rigidity: precision linear guide with 2 slides
3. Safety mechanism: moving to upper limit when servo or power off.

Please visit  
<http://www.magtronics.com.tw>  
 for drawing update.

				<b>VCM1</b>		
		Name	Date	Magtronics Tech. Inc.		
		Author	DL			2009/3/17
		Checked				
		Approved				
				VCM1	1 / 1	
				AS		